



MODULAR CUBER

IM-130ANE-HC
IM-130ANE-HC-23

PARTS LIST

[HE] [GRAM]

M037
M037-D001,D002,D003,D020



PLATON SERVICE

8 (800) 500-34-47

www.platonservice.com

D-1 OCT.2014
G-1 APR.2017
G-2 VOV.2017
J-1 JUL. 2019
J-2 SEP. 2019

List of Specifications

IM-130ANE-HC	M037	Standard
IM-130ANE-HC-23	M037-D001	23mm ICE of IM-130ANE-HC
IM-130ANE-HC	M037-D002	SUS316 FRAME of IM-130ANE-HC
IM-130ANE-HC-23	M037-D003	23mm ICE, SUS316 FRAME of IM-130ANE-HC
IM-130ANE-HC	M037-D020	For GRAM

Auxiliary Codes

Auxiliary Code Breakdown

The auxiliary code is the first two characters in the serial number. The first character indicates the year. Years progress or regress in alphabetical order. The series runs from "A" through "V" and the letters "I" and "O" are skipped. The second character indicates significant part changes within a year. Base is "0" and this number advances for each change. In cases where there is a letter in parentheses, this designates the month. This is the last character in the serial number. The series runs from "(A)" through "(M)" and the letter "(I)" is skipped. This designation is only included when identifying a parts change within an auxiliary code.

Note About Ordering Parts

Most assemblies cannot be ordered as complete units; parts in the assemblies generally must be ordered separately.

MARKS LOCATED UNDER THE AUXILIARY CODE

- = Part deleted.

FASTENER PART NUMBER

SCREWS

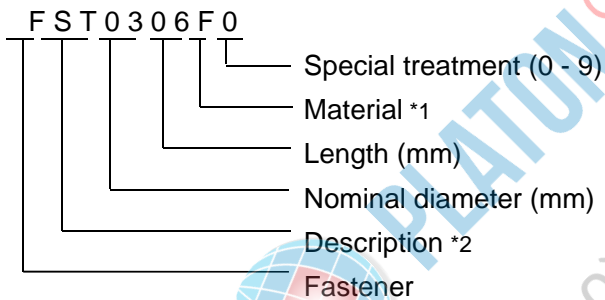

*1 **Material**

F: Steel
S: Austenitic stainless steel
M: Martensitic stainless steel
B: Copper alloy
P: Polycarbonate
N: Polyamide
V: PVC
A: ABS
X: Polyacetal
L: Aluminum

NUTS & WASHERS

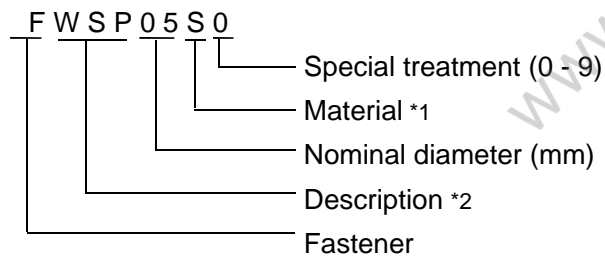

*2 **Description**

First letter
S: Machine screw
T: Tapping screw
M: Wood screw
B: Bolt
W: Washer
N: Nut

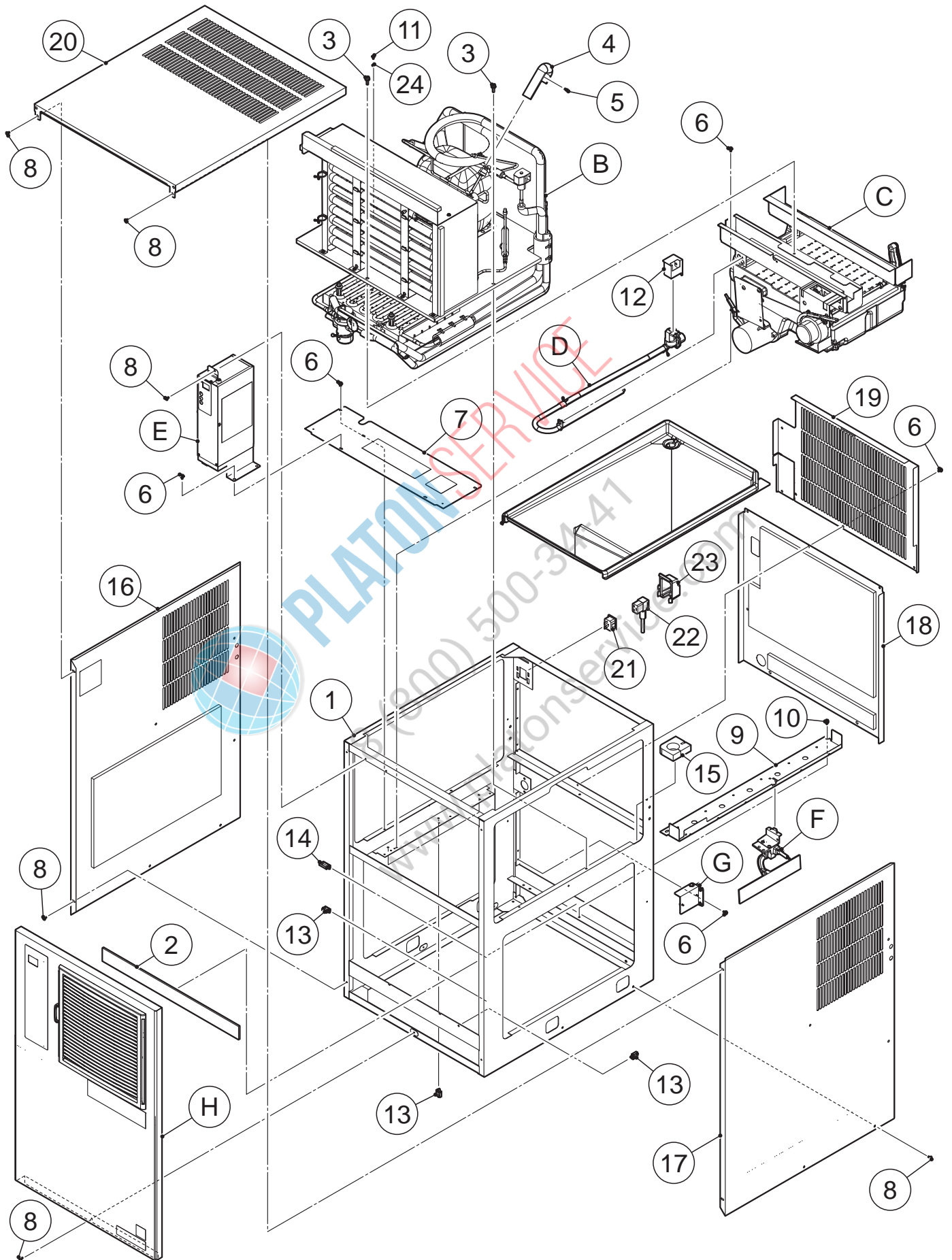

HE, GRAM

MODEL: IM-130ANE-HC IM-130ANE-HC-23		TITLE: A. ICE CUBER ASSY						
INDEX NO.	DESCRIPTION	MATERIAL OR MODEL NUMBER	PART NUMBER	REQ'D NUMBER				
				D-1 G-0	G-1	G-2 J-0	J-1	J-2
B	REFRIGERATION ASSY	IM-130ANE-HC-23	123249A01	1	1	-	-	-
			1H6014A01	-	-	1	1	1
			123249001	1	1	1	1	-
			1H6014001	-	-	-	-	1
C	MECHANISM ASSY		123247A01	1	1	1	1	1
D	WATER CIRCUIT ASSY		266660A01	1	1	1	1	1
E	CONTROL BOX ASSY	IM-130ANE-HC-23	122306A02	1	1	-	-	-
			2X3382A02	-	-	1	-	-
			2X3382A04	-	-	-	1	1
			122306A02	1	1	1	1	-
			2X3382A02	-	-	-	-	1
F	BIN SWITCH-2 ASSY		3Y5468A01	1	1	1	1	1
G	GAS SENSOR ASSY		480193A01	1	1	1	1	1
H	FRONT COVER ASSY	(HE)	263633A01	1	1	1	1	1
		(GRAM)	263633A02	1	1	1	1	1
R	ACCESSORIES		A02690-01	1	1	1	1	1
S	OPTIONAL PARTS		OPT-E1CP	1	1	1	1	1
1	UNIT FRAME		1H4740G01	1	1	1	1	1
		(SUS316)	1H5537G01					
2	INSULATION-FRAME (A)		4Y6982P01	1	1	1	1	1
3	HEX HEAD BOLT (SPRING WASHER AND FLAT WASHER)		FBK0620S0	4	4	4	4	4
4	Insulation Tube		H71527130	1	1	1	1	1
5	TIE	CV-150N,T30R	7920-0003	1	1	1	1	1
6	Flange Bolt (C-TITE)		FTR0408M0	21	21	21	21	21
7	COVER - FRAME		377461G01	1	1	1	1	1
8	S-TITE TRUSS HEAD SCREW		FTS0408M0	16	16	16	16	16
9	FRAME - BIN SWITCH		380499M01	1	1	1	1	1
10	HEX HEAD BOLT (SPRING WASHER AND FLAT WASHER)		FBK0508S0	2	2	2	2	2
11	TRUSS HEAD SCREW		FST0408S0	1	1	1	1	1
12	COVER-WATER VALVE		3Y6277M01	1	1	1	1	1
13	WIRE SADDLE		428060-03	5	5	5	5	5

HE, GRAM

MODEL: IM-130ANE-HC IM-130ANE-HC-23		TITLE: A. ICE CUBER ASSY						
INDEX NO.	DESCRIPTION	MATERIAL OR MODEL NUMBER	PART NUMBER	REQ'D NUMBER				
				D-1 G-0	G-1	G-2 J-0	J-1	J-2
14	WIRE SADDLE		428060-02	1	1	1	1	1
15	INSULATION		4Y0306-01	1	1	1	1	1
16	SIDE PANEL (L)		263627G01	1	1	1	1	1
17	SIDE PANEL (R)		263630G01	1	1	1	1	1
18	REAR PANEL		3Y5785G01	1	1	1	1	1
19	REAR PANEL UP		2X0612M01	1	1	1	1	1
20	TOP PANEL		2X0236M01	1	1	1	1	1
21	CONNECTOR		P00246-01	1	1	1	1	1
22	POWER SUPPLY CORD	CONT Plug	P03362-01	1	1	1	1	1
		UK Plug	P03363-01	1	1	1	1	1
24	COVER-CONNECTOR		2X0271P01	1	1	1	1	1
25	SPRING WASHER		FWSP04S0	1	1	1	1	1



8 (800) 500-3222
www.platonservice.com

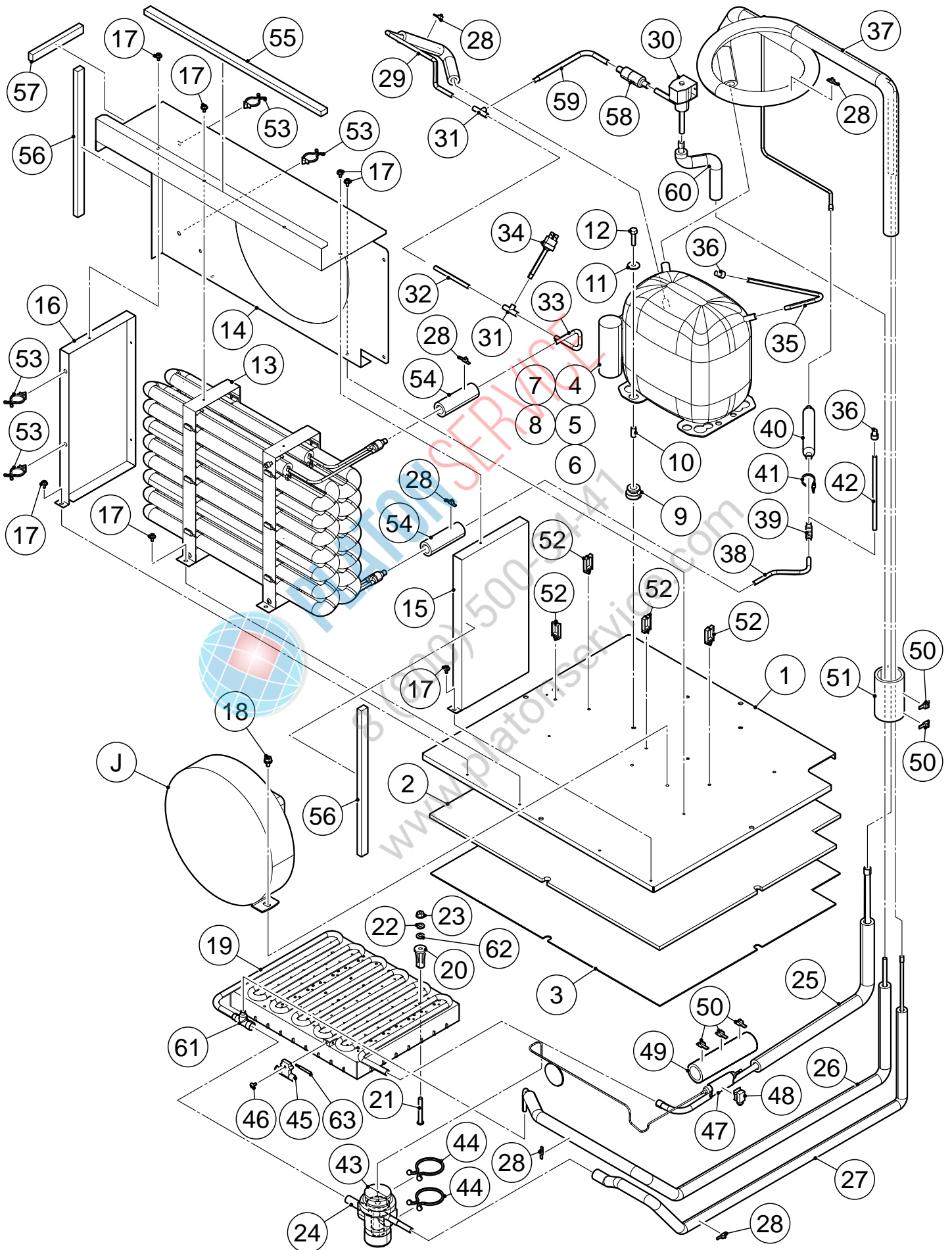

HE, GRAM

MODEL: **IM-130ANE-HC**
IM-130ANE-HC-23

TITLE: **B. REFRIGERATION ASSY**

INDEX NO.	DESCRIPTION	MATERIAL OR MODEL NUMBER	PART NUMBER	REQ'D NUMBER				
				D-1 G-0	G-1	G-2 J-0	J-1	J-2
J	FAN MOTOR ASSY		380423A01	1	1	1	1	1
1	BASE		380382G01	1	1	1	1	1
2	INSULATION - BASE		4Y6898P01	1	1	1	1	1
3	PLATE/BASE		4Y0249-01	1	1	1	1	1
4	COMPRESSOR		P03539-01	1	1	1	1	1
5	STARTING RELAY		P03540-01	1	1	1	1	1
6	COVER		P01179-01	1	1	1	1	1
7	START CAPACITOR		456350-01	1	1	1	1	1
8	CORD RELIEF		452239-01	1	1	1	1	1
9	GROMMET		450897-01	4	4	4	4	4
10	BUSH CUSHION		450895-01	4	4	4	4	4
11	WASHER CUSHION		450894-01	4	4	4	4	4
12	BOLT		4A1459-01	4	4	4	4	4
13	CONDENSER ASSY		266549G01	1	1	1	1	1
14	SHROUD		380386M01	1	1	1	1	1
15	SHROUD (R) - SIDE		380387M01	1	1	1	1	1
16	SHROUD (L) - SIDE		380388M01	1	1	1	1	1
17	Flange Bolt (C-TITE)		FTR0408M0	14	14	14	14	14
18	HEX HEAD BOLT (SPRING WASHER AND FLAT WASHER)		FBK0612F0	2	2	2	2	2
19	EVAPORATOR		2H6438G03	1	1	-	-	-
			2X2463G01	-	-	1	1	1
	EVAPORATOR 23MM	IM-130ANE-HC-23	2H1836G01	1	1	1	1	-
			2X2590G01	-	-	-	-	1
20	COLLAR		3H3879-01	4	4	4	4	4
21	SCREW EVAPORATOR		4Y4922M02	4	4	4	4	4
		IM-130ANE-HC-23	4Y4922M03	4	4	4	4	4
22	WASHER		4H0777-01	4	4	4	4	4
23	FLANGE NUT		FNHF06S0	4	4	4	4	4
24	EXPANSION VALVE		P03545-01	1	1	1	1	1
25	COPPER TUBE (A) - LOW SIDE		380403G01	1	1	1	1	1
26	COPPER TUBE (C) - HG		266544G01	1	1	1	1	1
27	COPPER TUBE (D) - H		266543G01	1	1	1	1	1

HE, GRAM

MODEL: **IM-130ANE-HC**
IM-130ANE-HC-23

TITLE: **B. REFRIGERATION ASSY**

INDEX NO.	DESCRIPTION	MATERIAL OR MODEL NUMBER	PART NUMBER	REQ'D NUMBER				
				D-1 G-0	G-1	G-2 J-0	J-1	J-2
28	TIE	CV-150N,T30R	7920-0003	6	6	6	6	6
29	COPPER TUBE (A) - H		380504G01	1	1	1	1	1
30	HOT GAS VALVE		P01871-01	1	1	1	1	1
31	TEE - 6.4		417394-01	2	2	2	2	2
32	COPPER TUBE (B) - H		480180M01	1	1	1	1	1
33	COPPER TUBE (C) - H		480181M01	1	1	1	1	1
34	PRESSURE SWITCH	R134a,R22,R404A,R290	459863-08	1	1	1	1	1
35	COPPER TUBE PROCESS		480178M01	1	1	1	1	1
36	LOCKRING STOPPER		P01677-01	2	2	2	2	2
37	HEAT EXCHANGER		266536G01	1	1	1	1	1
38	COPPER TUBE (A) - COND		480183M01	1	1	1	1	1
39	TEE		456655-01	1	1	1	1	1
40	DRIER		458776-01	1	1	1	1	1
41	PUSH MOUNT TIE		457167-01	1	1	1	1	1
42	COPPER TUBE (B) - COND		480184M01	1	1	1	1	1
43	VALVE COVER		3Y3051P01	1	1	1	1	1
44	CLAMP		P00752-01	2	2	2	2	2
45	HOLDER - THERMISTOR		315479-01	1	1	1	1	1
46	S-TITE TRUSS HEAD SCREW		FTS0408M0	1	1	1	1	1
47	HOLDER - EXP. VALVE 3/8		3A0107-01	1	1	1	1	1
48	CLAMP		443461-01	1	1	1	1	1
49	INSULATION		4X8643-01	2	2	2	2	2
50	NYLON TIE	CV-200N,T50R	7920-0010	5	5	5	5	5
51	Insulation Tube		H72636A80	1	1	1	1	1
52	WIRE SADDLE		428060-02	4	4	4	4	4
53	CLAMP		P04381-01	4	4	4	4	4
54	INSULATION TUBE		H71626A80	2	2	2	2	2
55	SPONGE TAPE		123249Z01	1	1	1	1	1
56	SPONGE TAPE		123249Z02	2	2	2	2	2
57	SPONGE TAPE		123249Z03	1	1	1	1	1
58	STRAINER		P00812-01	1	1	1	1	1
59	COPPER TUBE (A) - HG		480182M01	1	1	1	1	1
60	COPPER TUBE (D) - HG		380400G01	1	1	1	1	1

HE, GRAM

MODEL: IM-130ANE-HC IM-130ANE-HC-23		TITLE: B. REFRIGERATION ASSY						
INDEX NO.	DESCRIPTION	MATERIAL OR MODEL NUMBER	PART NUMBER	REQ'D NUMBER				
				D-1 G-0	G-1	G-2 J-0	J-1	J-2
61	TEE		420335-01	1	1	1	1	1
62	WASHER	IM-130ANE-HC-23	4H1365-05	4	4	4	4	4
63	THERMISTOR-CUBE CONTROL		P00350-01	1	1	1	1	1



PLATON SERVICE

8 (800) 500-34-47

www.platonservice.com

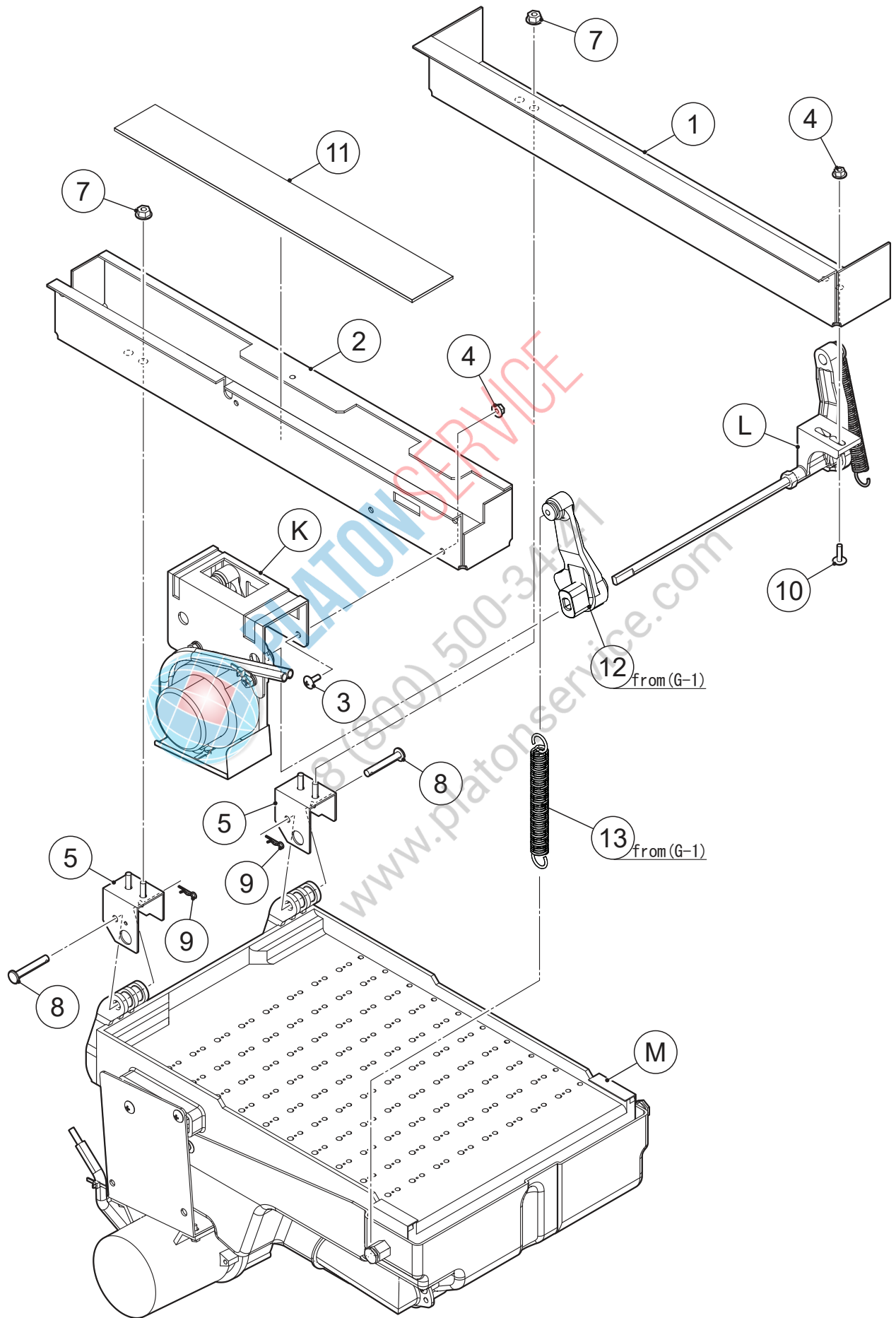

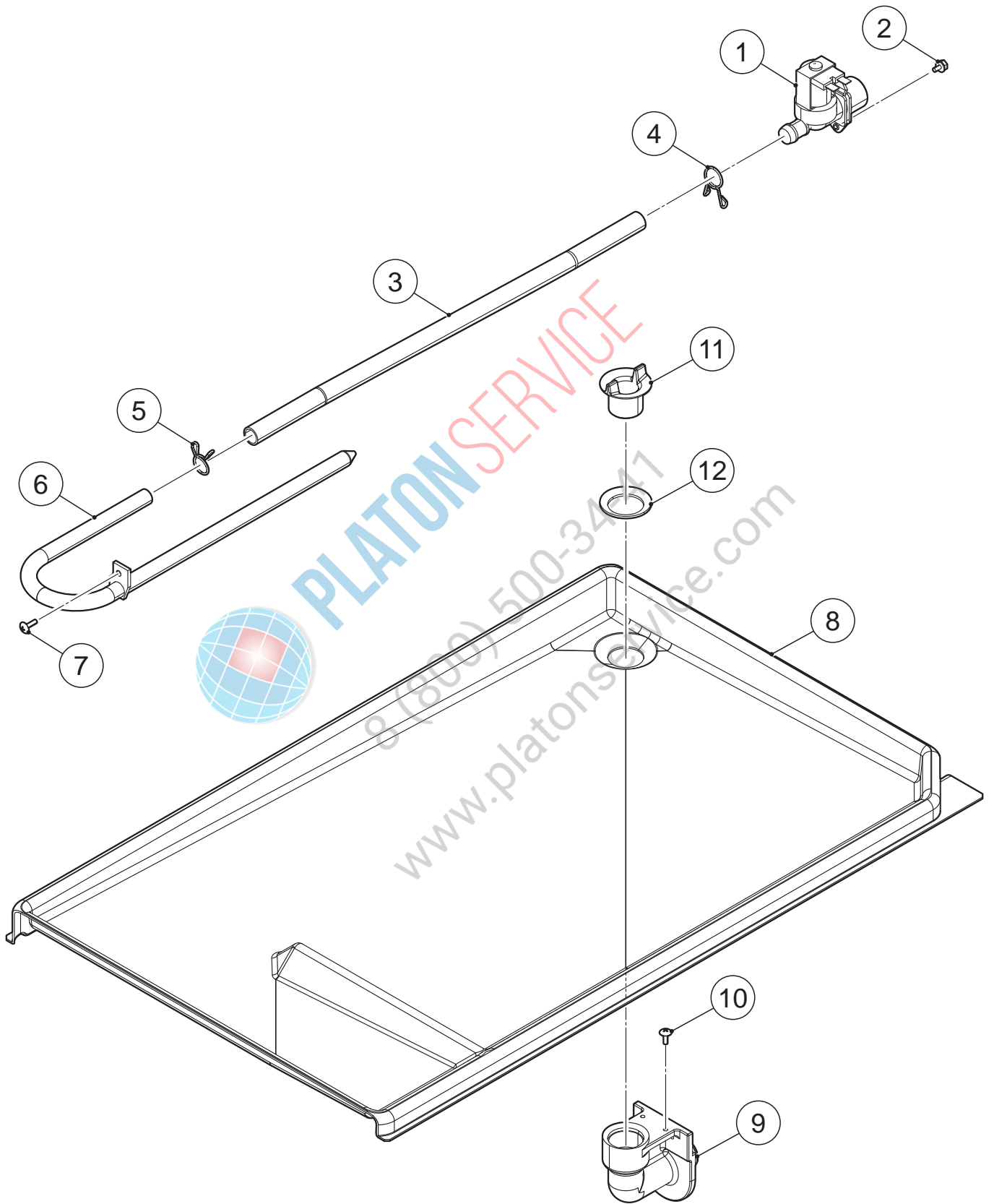

HE, GRAM

MODEL: IM-130ANE-HC IM-130ANE-HC-23		TITLE: D. WATER CIRCUIT ASSY						
INDEX NO.	DESCRIPTION	MATERIAL OR MODEL NUMBER	PART NUMBER	REQ'D NUMBER				
				D-1 G-0	G-1	G-2 J-0	J-1	J-2
1	WATER VALVE		P05355-01	1	1	1	1	1
2	HEX HEAD BOLT (SPRING WASHER AND FLAT WASHER)		FBK0408S0	2	2	2	2	2
3	SILICONE HOSE		4Y6912R05	1	1	1	1	1
4	HOSE CLAMP		435934-03	1	1	1	1	1
5	HOSE CLAMP		435934-02	1	1	1	1	1
6	WATER SUPPLY PIPE		3H9532G01	1	1	1	1	1
7	TRUSS HEAD SCREW		FST0412S0	1	1	1	1	1
8	DRAIN PAN		125283P02	1	1	1	1	1
9	DRAIN PIPE		315825-01	1	1	1	1	1
10	T2 TRUSS HEAD SCREW		FT20410M0	2	2	2	2	2
11	DRAIN YOKE		418296-01	1	1	1	1	1
12	PACKING		413857-01	1	1	1	1	1



8 (800) 500-3444
www.platonservice.com

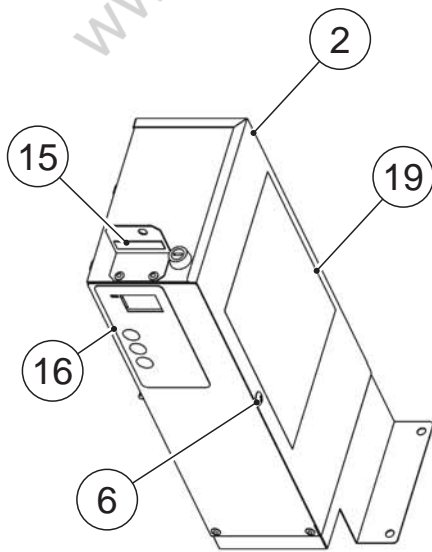
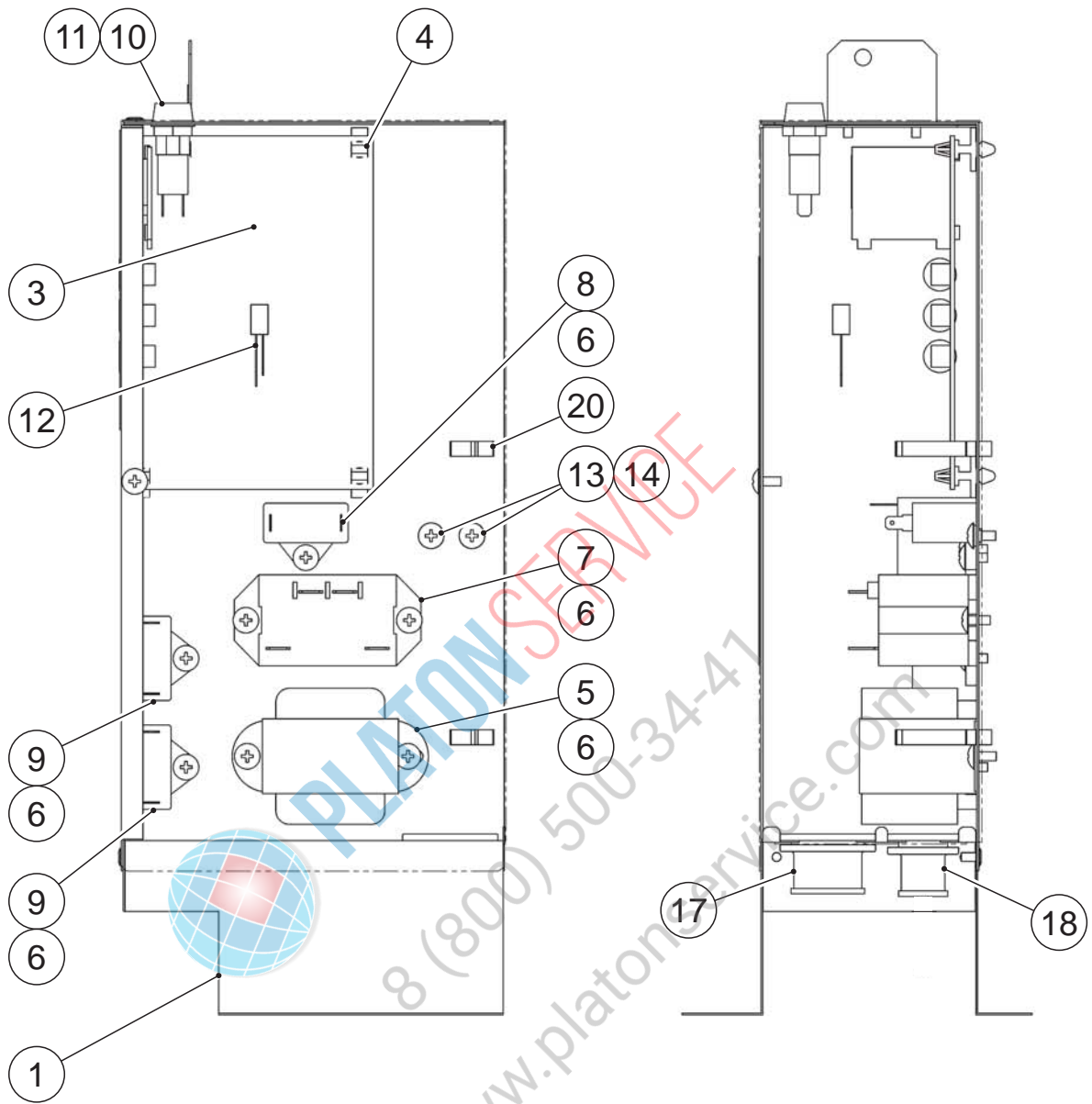

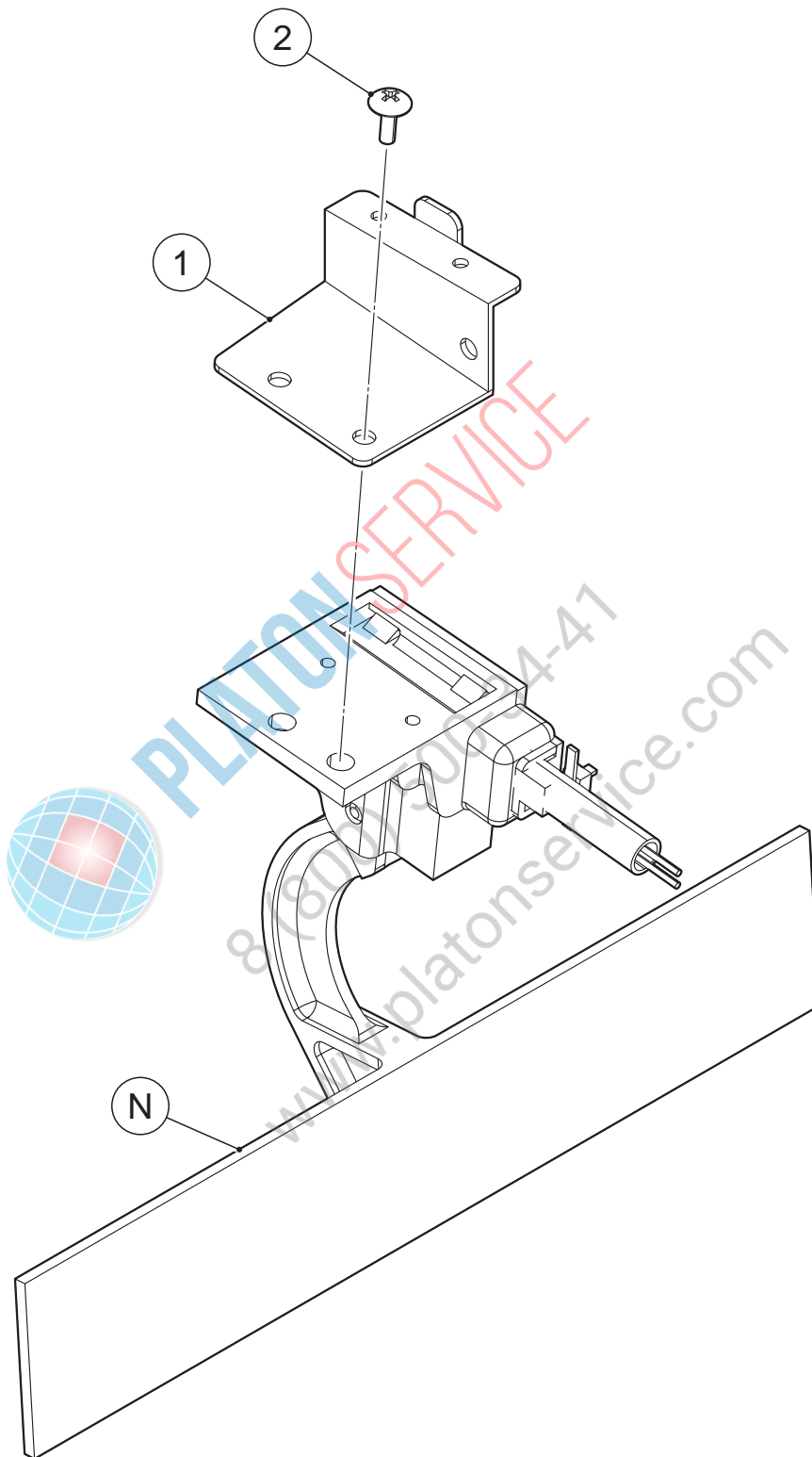

HE, GRAM

MODEL: IM-130ANE-HC IM-130ANE-HC-23		TITLE: F. BIN SWITCH-2 ASSY						
INDEX NO.	DESCRIPTION	MATERIAL OR MODEL NUMBER	PART NUMBER	REQ'D NUMBER				
				D-1 G-0	G-1	G-2 J-0	J-1	J-2
N	BIN SWITCH ASSY		3Y5380A01	1	1	1	1	1
1	BRACKET-BIN SWITCH		4Y6892M01	1	1	1	1	1
2	T2 TRUSS HEAD SCREW		FT20410M0	2	2	2	2	2



PLATON SERVICE

8 (800) 500-34-47

www.platonservice.com

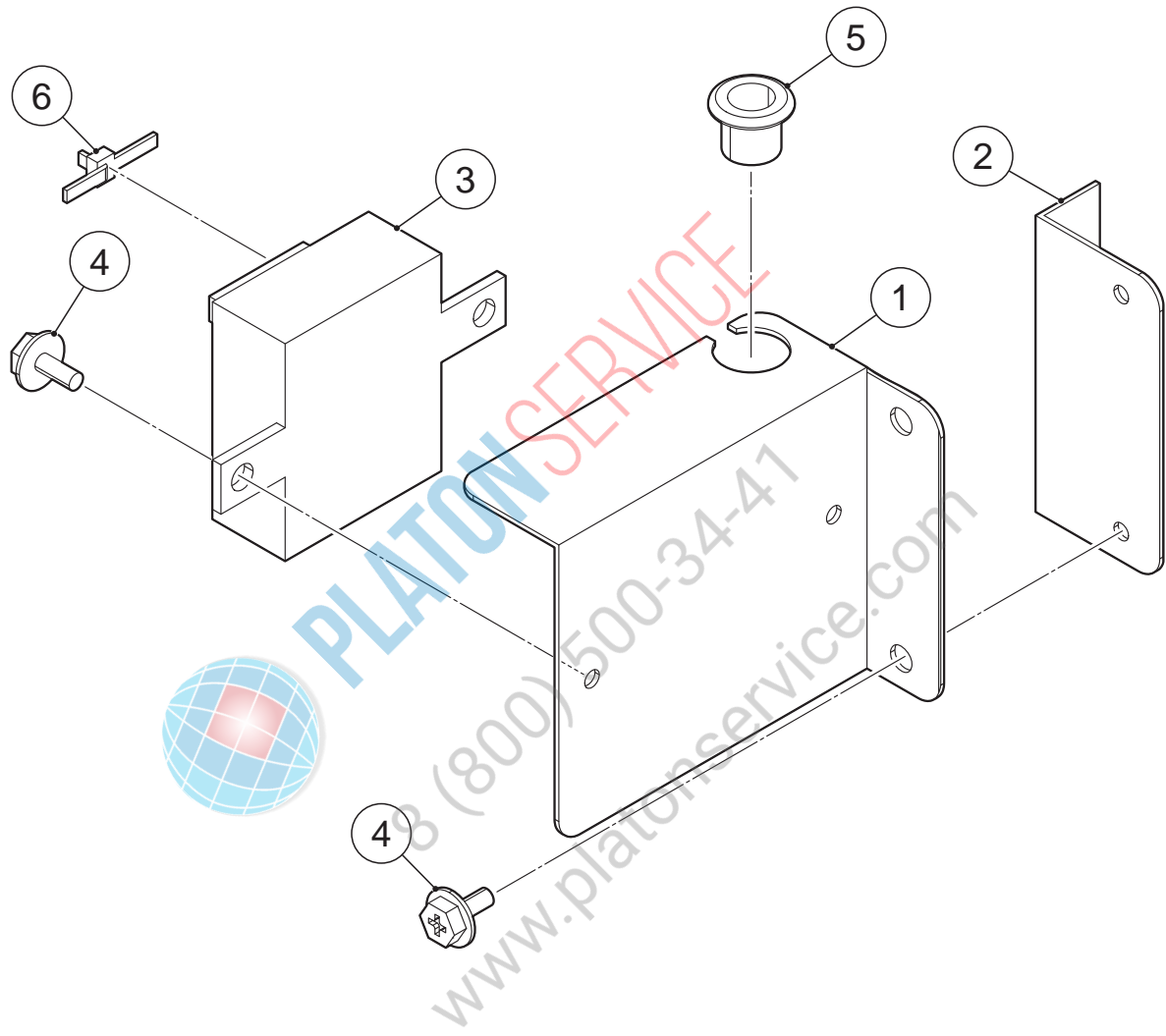

HE, GRAM

MODEL: IM-130ANE-HC IM-130ANE-HC-23		TITLE: G. GAS SENSOR ASSY						
INDEX NO.	DESCRIPTION	MATERIAL OR MODEL NUMBER	PART NUMBER	REQ'D NUMBER				
				D-1 G-0	G-1	G-2 J-0	J-1	J-2
1	BRACKET (A) - SENSOR		380424M01	1	1	1	1	1
2	BRACKET (B) - SENSOR		480192M01	1	1	1	1	1
3	GAS SENSOR	8500ppm	P02756-03	1	1	1	1	1
4	Flange Bolt (C-TITE)		FTR0408M0	4	4	4	4	4
5	BUSHING		428394-02	1	1	1	1	1
6	NYLON TIE	CV-70N,T18S	7920-0001	1	1	1	1	1



PLATON SERVICE
 8 (800) 500-34-41
www.platonservice.com

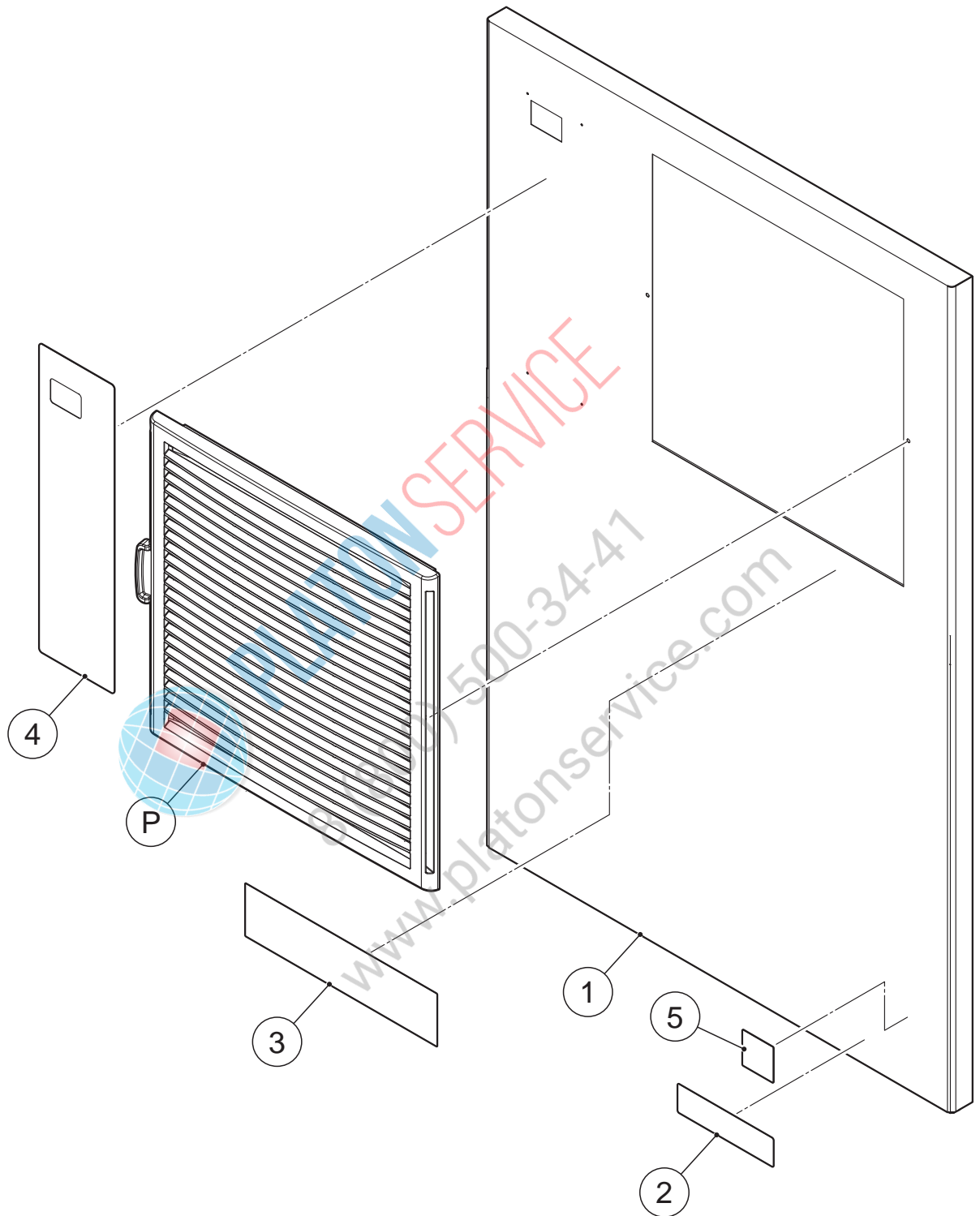

HE, GRAM

MODEL: IM-130ANE-HC IM-130ANE-HC-23		TITLE: H. FRONT COVER ASSY						
INDEX NO.	DESCRIPTION	MATERIAL OR MODEL NUMBER	PART NUMBER	REQ'D NUMBER				
				D-1 G-0	G-1	G-2 J-0	J-1	J-2
P	LOUVER ASSY		377439A01	1	1	1	1	1
1	FRONT COVER		263634G01	1	1	1	1	1
2	LABEL - HFCFREE		373508L01	1	1	1	1	1
3	WARNING LABEL - RISK OF FIRE		377581L01	1	1	1	1	1
4	OPERATION LABEL	(HE)	377582L01	1	1	1	1	1
		(GRAM)	381211L01	1	1	1	1	1
5	LABEL - HACCP		476519L01	1	1	1	1	1



PLATON SERVICE
 8 (800) 500-34-41
www.platonservice.com

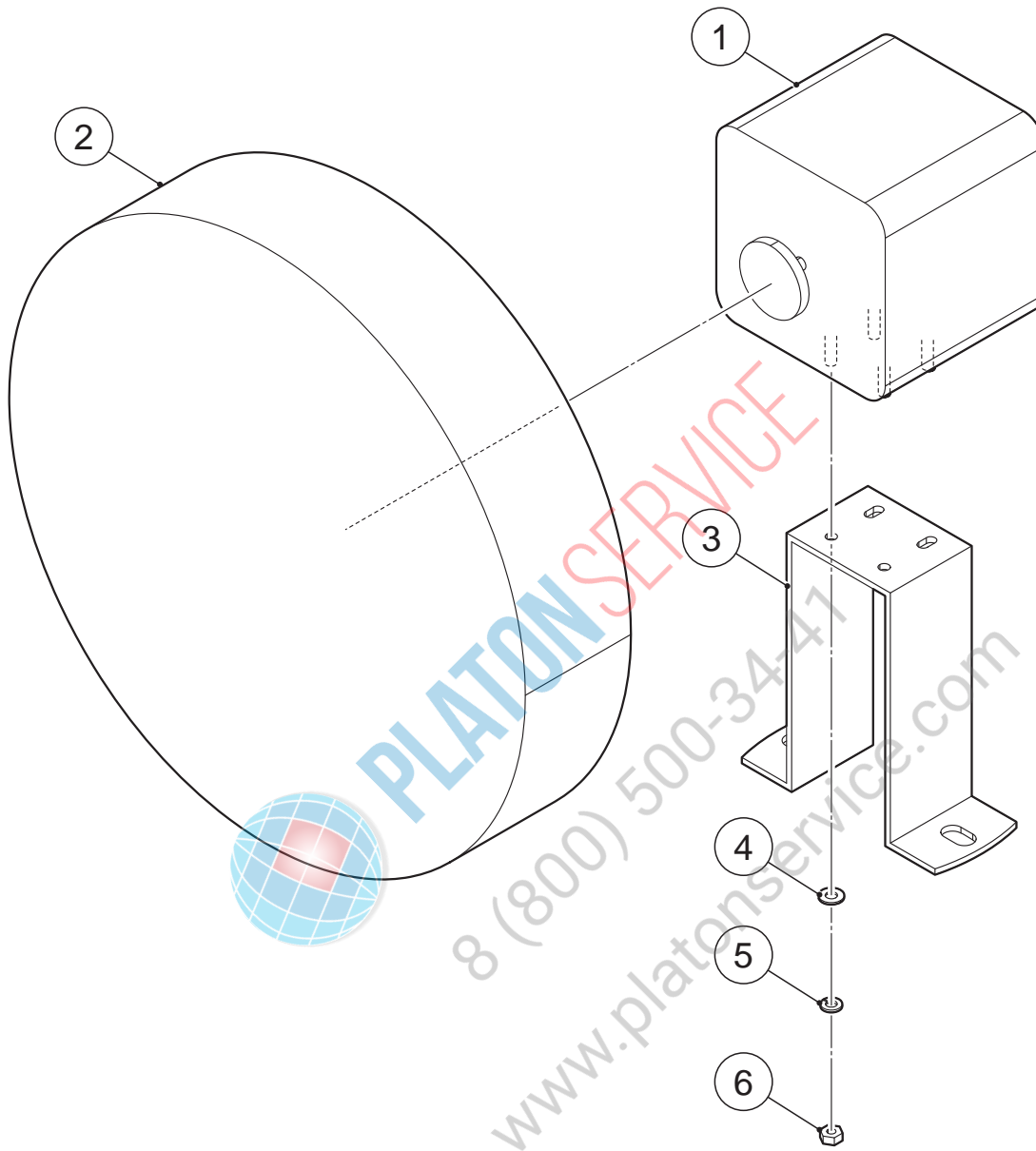

HE, GRAM

MODEL: IM-130ANE-HC IM-130ANE-HC-23		TITLE: J. FAN MOTOR ASSY						
INDEX NO.	DESCRIPTION	MATERIAL OR MODEL NUMBER	PART NUMBER	REQ'D NUMBER				
				D-1 G-0	G-1	G-2 J-0	J-1	J-2
1	FAN MOTOR		P02528-01	1	1	1	1	1
2	FAN BLADE		P03551-01	1	1	1	1	1
3	BRACKET - FM		3Y6143M01	1	1	1	1	1
4	FLAT WASHER		FWPL04S0	4	4	4	4	4
5	SPRING WASHER		FWSP04S0	4	4	4	4	4
6	NUT		FNH104S0	4	4	4	4	4



PLATON SERVICE
8 (800) 500-34-41
www.platonservice.com

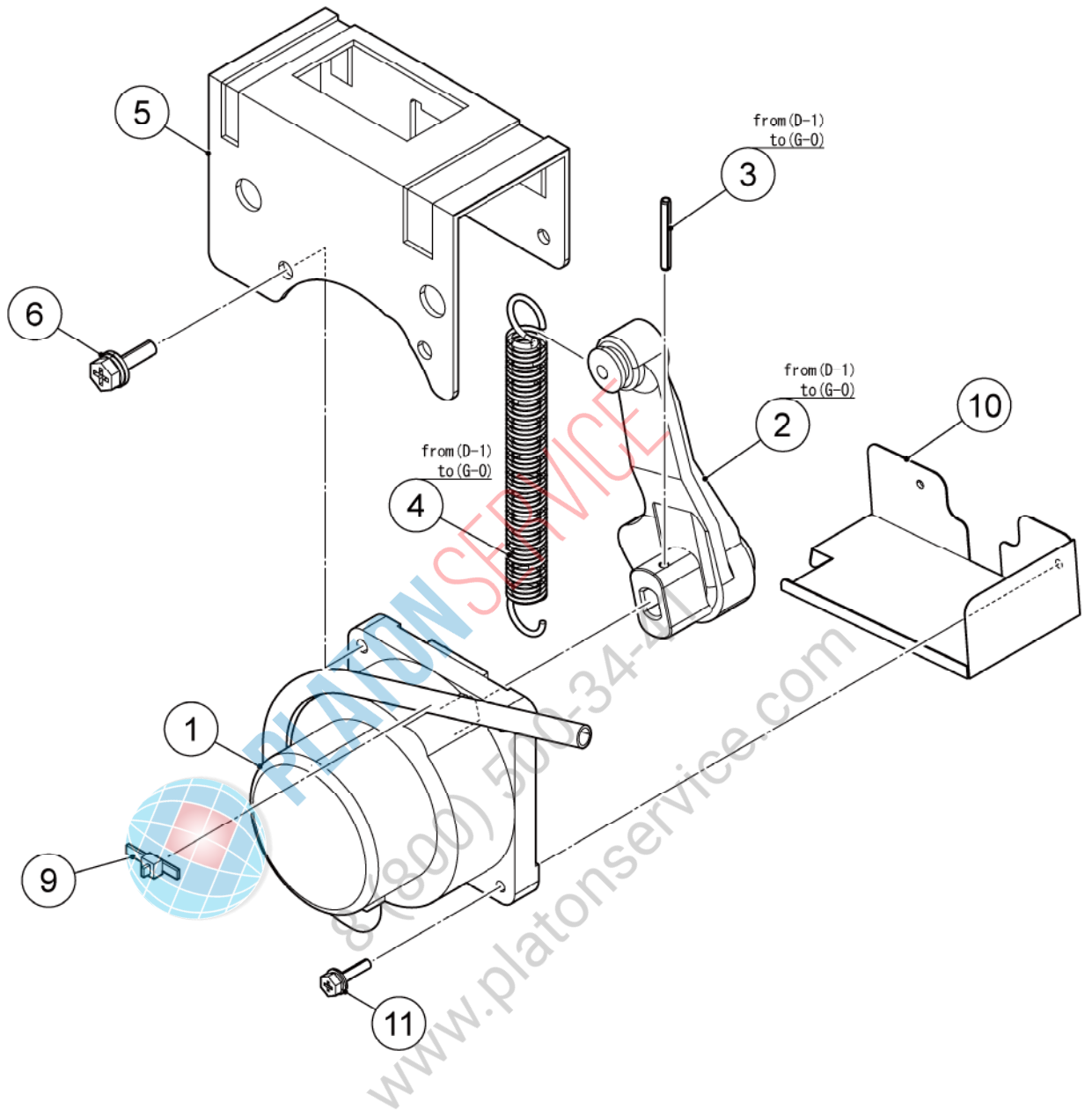

HE, GRAM

MODEL: IM-130ANE-HC IM-130ANE-HC-23		TITLE: K. ACTUATOR MOTOR ASSY						
INDEX NO.	DESCRIPTION	MATERIAL OR MODEL NUMBER	PART NUMBER	REQ'D NUMBER				
				D-1 G-0	G-1	G-2 J-0	J-1	J-2
1	ACTUATOR MOTOR		4Y8998G01	1	1	1	1	1
2	CAM(A)		306543G03	1	-	-	-	-
3	SPRING PIN 3*28		712S-0328	1	-	-	-	-
4	SPRING		4H0287-01	1	-	-	-	-
5	BRACKET-AM		3Y2924M01	1	1	1	1	1
6	HEX HEAD BOLT (SPRING WASHER AND FLAT WASHER)		FBK0620S0	2	2	2	2	2
7	TUBE-SILICONE		4Y6751Z02	-	-	-	-	-
8	TUBE-SILICONE		4X8017-07	-	-	-	-	-
9	TIE	CV-150N,T30R	7920-0003	1	1	1	1	1
10	COVER-AM		3Y7525M01	1	1	1	1	1
11	HEX HEAD BOLT (SPRING WASHER AND FLAT WASHER)		FBK0416S0	2	2	2	2	2



8 (800) 500-3344
www.platonservice.com

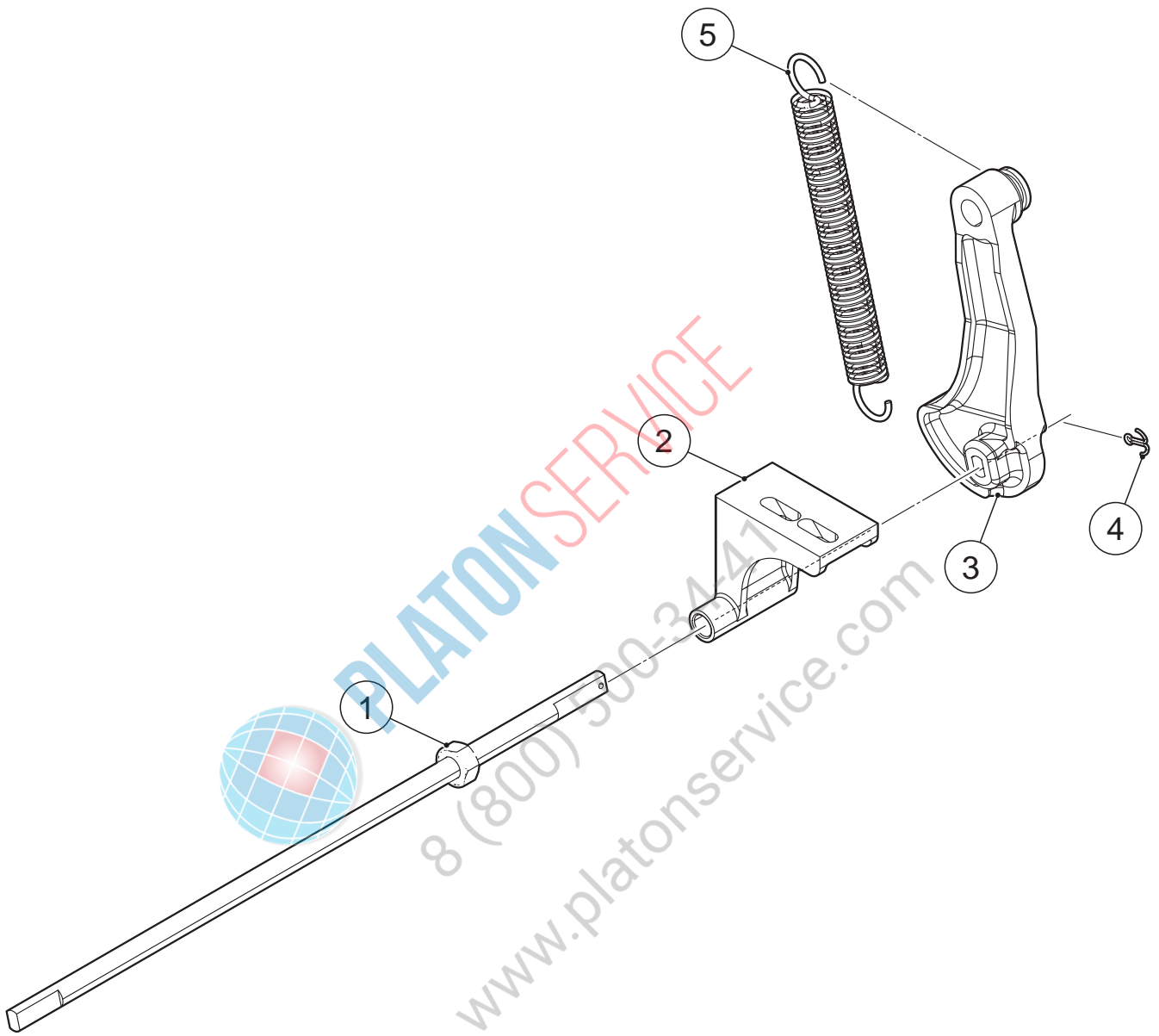

HE, GRAM

MODEL: IM-130ANE-HC IM-130ANE-HC-23		TITLE: L. CAM SHAFT ASSY						
INDEX NO.	DESCRIPTION	MATERIAL OR MODEL NUMBER	PART NUMBER	REQ'D NUMBER				
				D-1 G-0	G-1	G-2 J-0	J-1	J-2
1	CAM SHAFT		4H2702G02	1	1	1	1	1
2	BEARING-CAM SHAFT		3X8307-02	1	1	1	1	1
3	CAM(B)		376546P01	1	1	1	1	1
4	COTTER PIN		711S-0212	1	1	1	1	1
5	SPRING		4H0287-01	1	1	1	1	1



PLATON SERVICE
8 (800) 500-34-41
www.platonservice.com

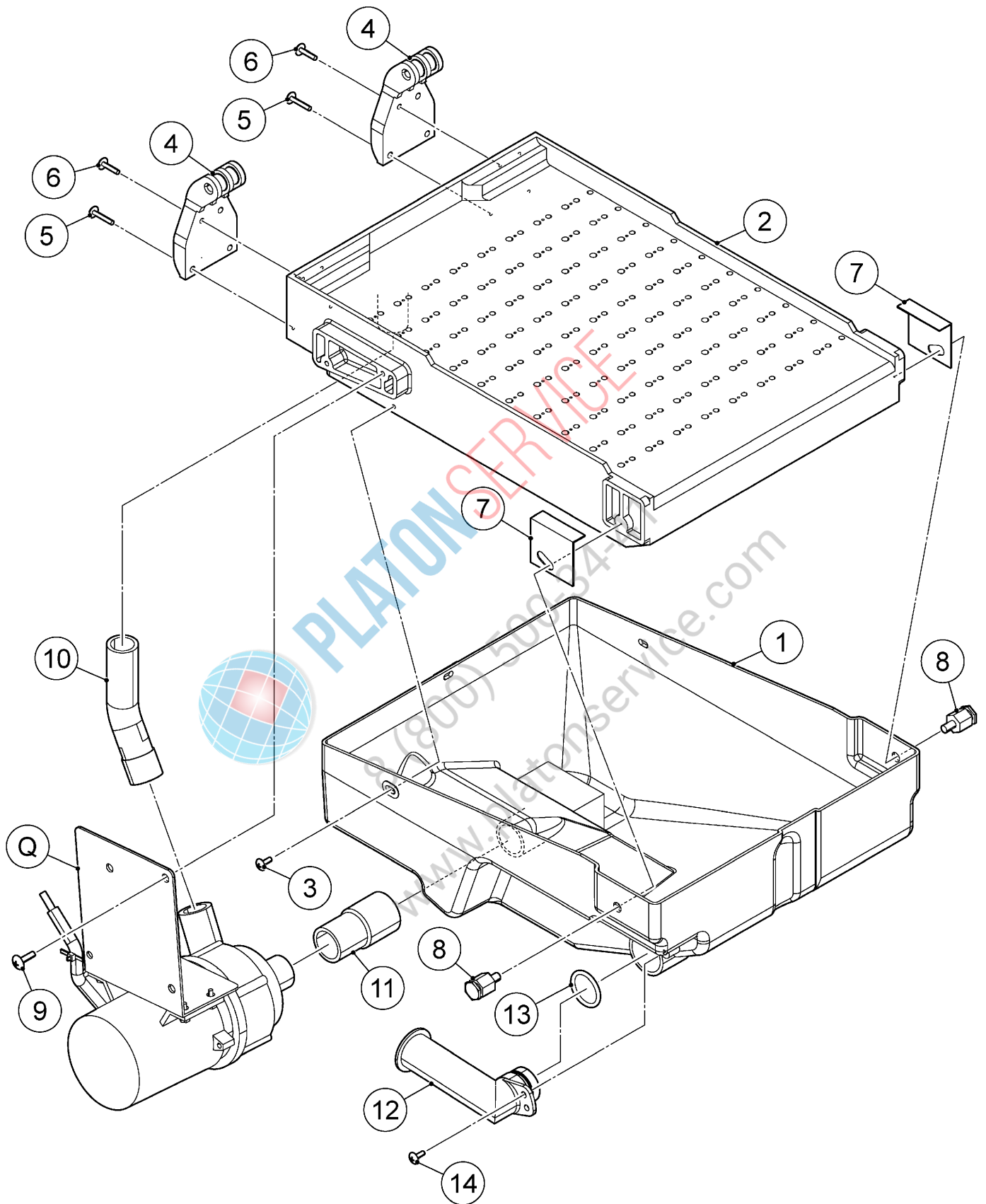

HE, GRAM

MODEL: IM-130ANE-HC IM-130ANE-HC-23		TITLE: M. WATER PAN ASSY						
INDEX NO.	DESCRIPTION	MATERIAL OR MODEL NUMBER	PART NUMBER	REQ'D NUMBER				
				D-1 G-0	G-1	G-2 J-0	J-1	J-2
Q	PUMP MOTOR ASSY		3Y5303A02	1	1	1	1	1
1	WATER TANK		2H2286G01	1	1	1	1	1
2	WATER PAN ASSY		2H0833G02	1	1	1	1	1
3	T2 TRUSS HEAD SCREW		FT20410M0	3	3	3	3	3
4	WATER PAN HANGER		3H2059-01	2	2	2	2	2
5	TRUSS HEAD TAPPING SCREW T2		FT20420M0	4	4	4	4	4
6	T2 TRUSS HEAD SCREW		FT20416M0	4	4	4	4	4
7	BRACKET		402957-01	2	2	2	2	2
8	SCREW SPRING HOOK		4H2582G01	2	2	2	2	2
9	TRUSS HEAD TAPPING SCREW T2		FT20516M0	2	2	2	2	2
10	TUBING - PUMP DISCHARGE		4Y7517G01	1	1	1	1	1
11	SUCTION TUBE		4Y7518G01	1	1	1	1	1
12	PIPE-DRAIN		315530-01	1	1	1	1	1
13	O-RING		7611-G025	1	1	1	1	1
14	TRUSS HEAD SCREW		FST0410S0	1	1	1	1	1

PLATON SERVICE

8 (800) 500-2222

www.platonservice.com

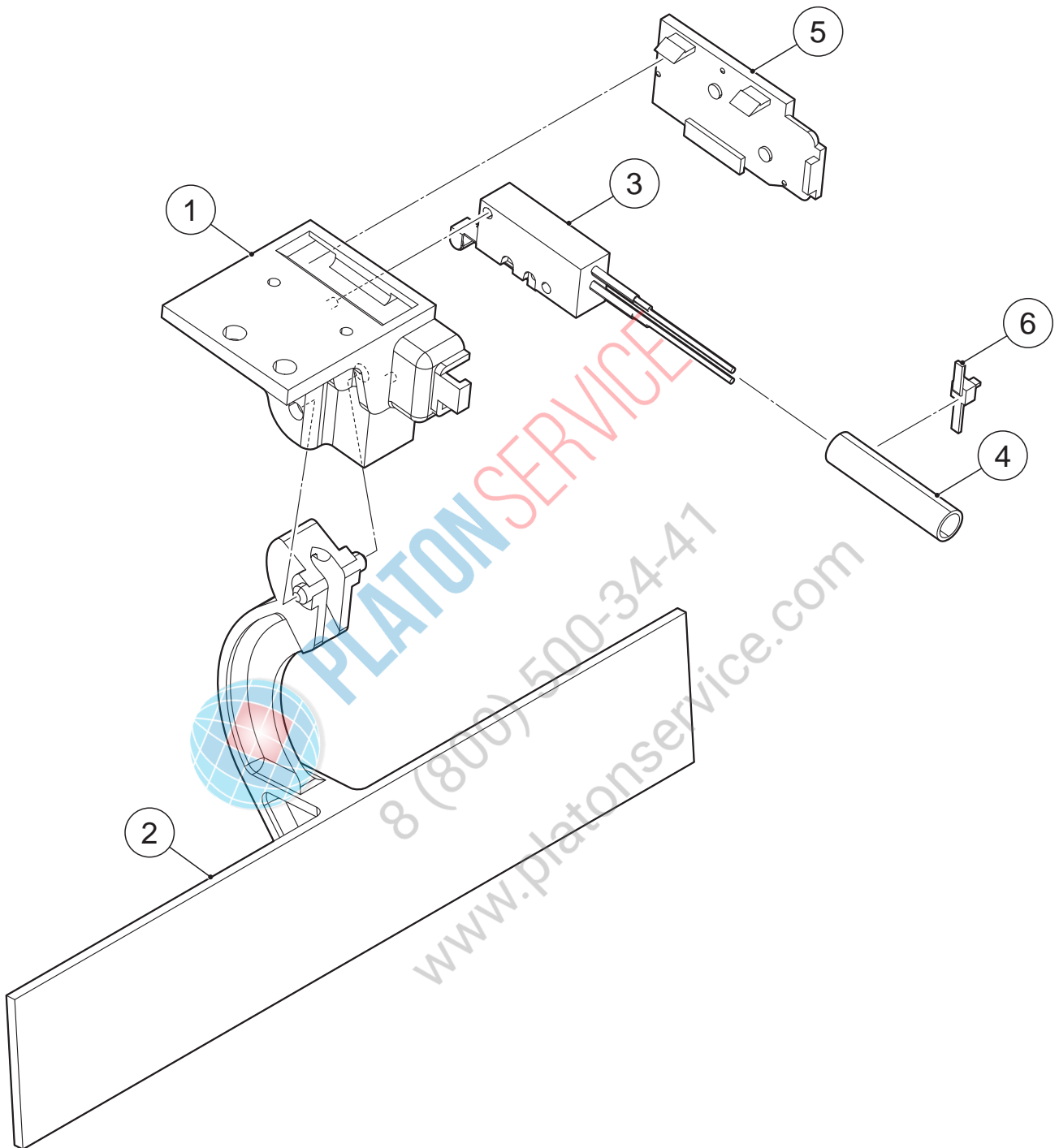

HE, GRAM

MODEL: IM-130ANE-HC IM-130ANE-HC-23		TITLE: N. BIN SWITCH ASSY						
INDEX NO.	DESCRIPTION	MATERIAL OR MODEL NUMBER	PART NUMBER	REQ'D NUMBER				
				D-1 G-0	G-1	G-2 J-0	J-1	J-2
1	SWITCH BOX		2H2043-01	1	1	1	1	1
2	SWITCH - ACTUATOR		2H7202-01	1	1	1	1	1
3	MICRO SWITCH		456432-01	1	1	1	1	1
4	TUBE-SILICONE		4X8017-03	1	1	1	1	1
5	SWITCH BOX COVER		4H8785-01	1	1	1	1	1
6	TIE	CV-100N,T18R	7920-0002	1	1	1	1	1



PLATON SERVICE
 8 (800) 500-34-41
www.platonservice.com

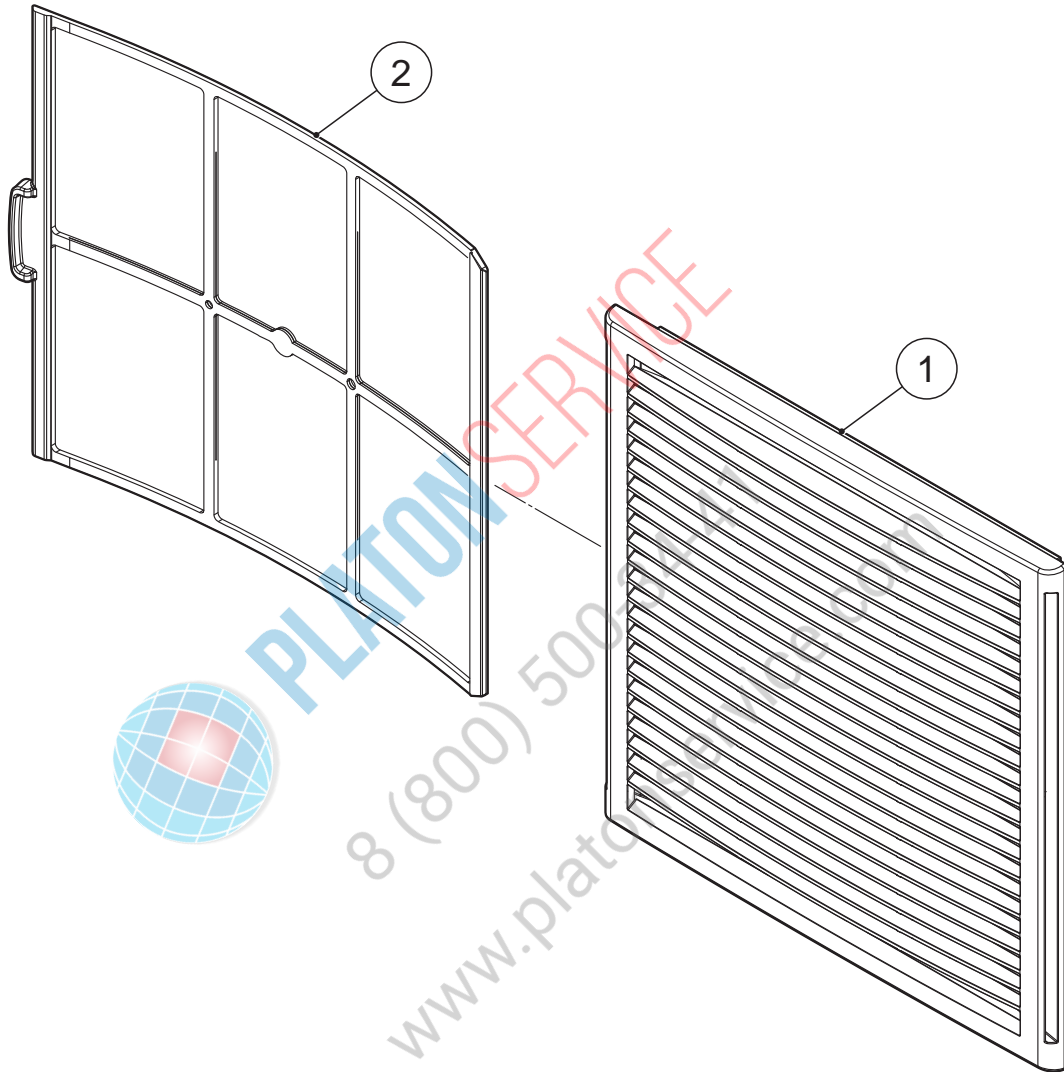

HE, GRAM

MODEL: IM-130ANE-HC IM-130ANE-HC-23		TITLE: P. LOUVER ASSY						
INDEX NO.	DESCRIPTION	MATERIAL OR MODEL NUMBER	PART NUMBER	REQ'D NUMBER				
				D-1 G-0	G-1	G-2 J-0	J-1	J-2
1	LOUVER		121931P01	1	1	1	1	1
2	AIR FILTER		262259G01	1	1	1	1	1



PLATON SERVICE

8 (800) 500-34-47

www.platonservice.com

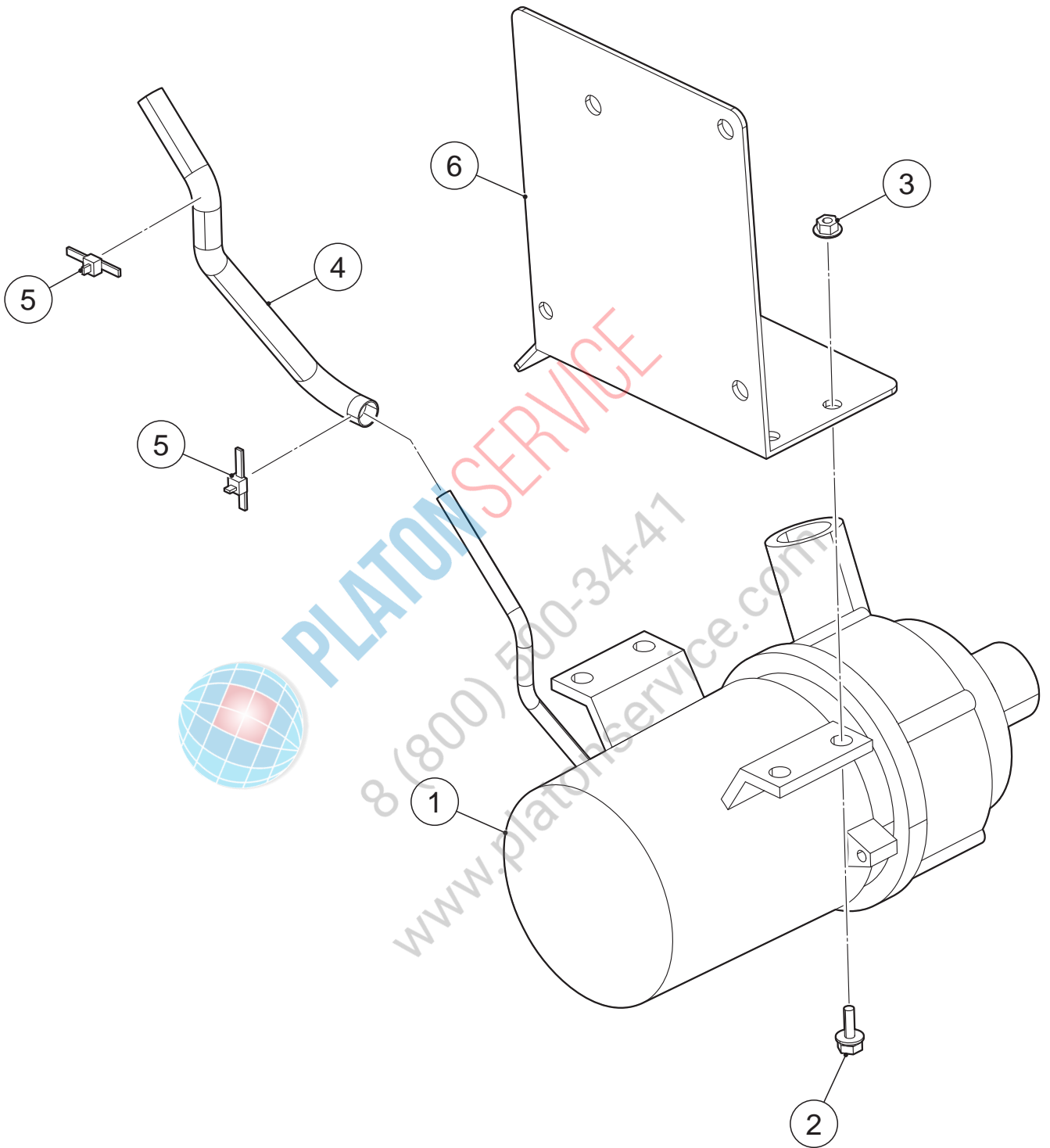

HE, GRAM

MODEL: IM-130ANE-HC IM-130ANE-HC-23		TITLE: Q. PUMP MOTOR ASSY						
INDEX NO.	DESCRIPTION	MATERIAL OR MODEL NUMBER	PART NUMBER	REQ'D NUMBER				
				D-1 G-0	G-1	G-2 J-0	J-1	J-2
1	PUMP MOTOR		P02715-01	1	1	1	1	1
2	HEX HEAD BOLT (SPRING WASHER AND FLAT WASHER)		FBK0412S0	4	4	4	4	4
3	FLANGE NUT		FNHF04S0	4	4	4	4	4
4	TUBE-SILICONE		4Y6751Z10	1	1	1	1	1
5	TIE	CV-100N,T18R	7920-0002	2	2	2	2	2
6	BRACKET - PUMP		4Y7503M01	1	1	1	1	1



PLATON SERVICE
8 (800) 500-34-41
www.platonservice.com

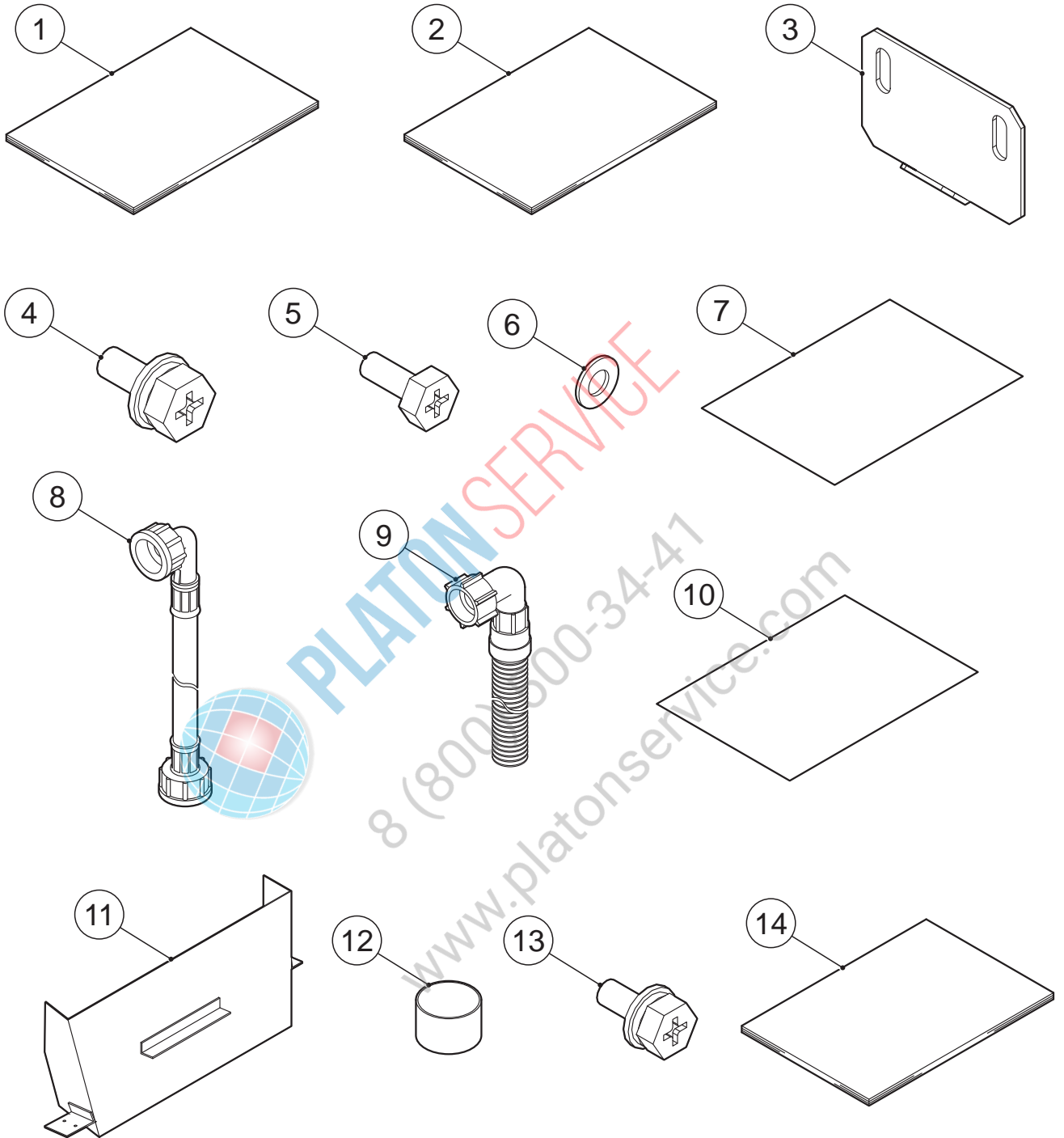

HE, GRAM

MODEL: IM-130ANE-HC IM-130ANE-HC-23		TITLE: R. ACCESSORIES						
INDEX NO.	DESCRIPTION	MATERIAL OR MODEL NUMBER	PART NUMBER	REQ'D NUMBER				
				D-1 G-0	G-1	G-2 J-0	J-1	J-2
1	INSTRUCTION MANUAL		L1E1GA203	1	1	1	1	1
2	INSTALLATION MANUAL		L2E1GA202	1	1	1	1	1
3	BRACE		4Y7310M01	2	2	2	2	2
4	HEX HEAD BOLT (SPRING WASHER AND FLAT WASHER)		FBK0510S0	2	2	2	2	2
5	HEX HEAD BOLT		FBH0408S0	2	2	2	2	2
6	FLAT WASHER		FWPL04S0	2	2	2	2	2
7	PE BAG (STANDARD)		7V91-0009	1	1	1	1	1
8	INLET HOSE		P03534-01	1	1	1	1	1
9	OUTLET HOSE		452365-01	1	1	1	1	1
10	PE BAG (STANDARD)		7V91-0013	1	1	1	1	1
11	ICE CHUTE		2H9759G01	1	1	1	1	1
12	CAP		417323-01	1	1	1	1	1
13	HEX HEAD BOLT (SPRING WASHER AND FLAT WASHER)		FBK0408S0	2	2	2	2	2
14	INSTRUCTION MANUAL		121594L01	1	1	1	1	1



PLATON SERVICE
8 (800) 500-2244
www.platonservice.com

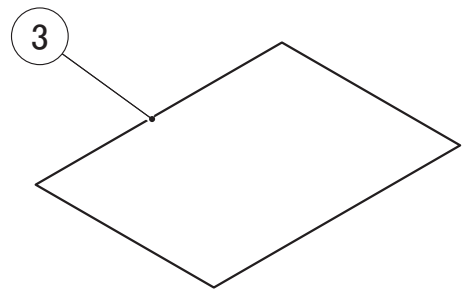
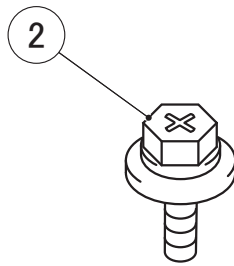
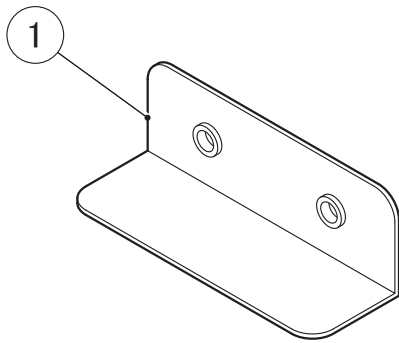

PLATON SERVICE

8 (800) 500-34-47

www.platonservice.com

HE, GRAM

MODEL: IM-130ANE-HC IM-130ANE-HC-23		TITLE: S. OPTIONAL PARTS						
INDEX NO.	DESCRIPTION	MATERIAL OR MODEL NUMBER	PART NUMBER	REQ'D NUMBER				
				D-1 G-0	G-1	G-2 J-0	J-1	J-2
1	PLATE-ICE CHUTE		4Y6284M01	1	1	1	1	1
2	HEX HEAD BOLT (SPRING WASHER AND FLAT WASHER)		FBK0408S0	2	2	2	2	2
3	INSTRUCTION SHEET		258216L01	1	1	1	1	1



PLATON SERVICE

8 (800) 500-34-47

www.platonservice.com